



### WALTON TAP EXTRACTORS

- Remove broken taps simply and safely – without drilling, lasers, damaged threads, scrapped parts or repair inserts.
- Available in every tap size, inch and metric.
- Available as sets (page 4) or individual pieces (page 3).



## 3 SIMPLE STEPS FOR REMOVING BROKEN TAPS THE EASY WAY!



**1** Thoroughly remove all chips of the broken tap. Insert the extractor fingers into the flutes of the broken tap, pushing them gently but firmly into position.



**2** Push the holder down until it touches the broken tap. Slide the sleeve down until it touches the work. (Both are important.)



**3** Apply a tap wrench to the square end of the holder. Twist forward and backward a few times to loosen, then back out the broken tap.

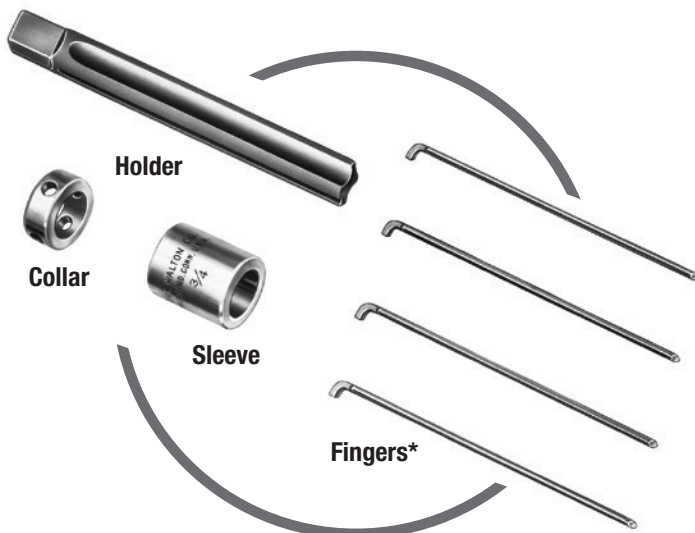

## TAP EXTRACTOR PARTS

\* For replacement fingers, minimum package quantity is 12.

# TAP EXTRACTORS









## SINGLE UNITS & REPLACEMENT PARTS



860-523-5231 • Fax: 860-236-9968 • WaltonTools.com

UPC No. 054808

### SINGLE UNITS and REPLACEMENT PARTS

WALTON Tap Extractor Size	COMPLETE TAP EXTRACTOR				EXTRA FINGERS			
	6-Flute	4-Flute	3-Flute	2-Flute	6-Flute	4-Flute	3-Flute	2-Flute
								
#4 (3mm)	--	--	10043	10042	--	--	12043	12042
#5 (1/8")(3.2mm)	--	--	10053	10052	--	--	12053	12052
#6 (3.5mm)	--	10064	10063	10062	--	12064	12063	12062
#8 (4mm)	--	10084	10083	10082	--	12084	12083	12082
#10 (3/16")(5mm)	--	10104	10103	10102	--	12104	12103	12102
#12 (5.5mm)	--	10124	10123	10122	--	12124	12123	12122
1/4" (6mm)	--	10254	10253	10252	--	12254	12253	12252
9/32" (7mm)	--	10284	--	--	--	12284	--	--
5/16" (7mm, 8mm)	--	10314	10313	10312	--	12314	12313	12312
11/32"	--	10344	--	--	--	12344	--	--
3/8" (9mm, 10mm)	--	10374	10373	10372	--	12374	12373	12372
13/32" (10mm)	--	10404	--	--	--	12404	--	--
7/16" (11mm)	--	10434	10433	10432	--	12434	12433	12432
1/2" (12mm)	--	10504	10503	10502	--	12504	12503	12502
9/16" (14mm)	--	10564	10563	--	--	12564	12563	--
5/8" (16mm)	--	10624	10623	--	--	12624	12623	--
11/16" (18mm)	--	10684	--	--	--	12684	--	--
3/4" (18mm, 20mm)	--	10754	10753	--	--	12754	12753	--
7/8" (22mm)	--	10874	10873	--	--	12874	12873	--
1" (24mm, 25mm)	--	11004	11003	--	--	13004	13003	--
1-1/8" (26-28mm)	11126	11124	--	--	13126	13124	--	--
1-1/4" (30-32mm)	11256	11254	--	--	13256	13254	--	--
1-3/8" (35-36mm)	11376	11374	--	--	13376	13374	--	--
1-1/2" (38mm)	11506	11504	--	--	13506	13504	--	--

EDP Part No. shown indicates available flute style for each size. 4-Flute style supplied, where available, unless otherwise specified. Parts are not interchangeable between flute styles. Also available in Complete Production Range Sets, as shown on page 4.

**REFER TO ORDERING INFORMATION ON PAGE 7.**

 **California Proposition 65 Warning**

**WARNING:** These products contains lead, a chemical known to the State of California to cause cancer, and birth defects or other reproductive harm.

For more information: [www.P65Warnings.ca.gov](http://www.P65Warnings.ca.gov).



**STANDARD SETS:  
Nos. 1, 2, 3**

Packed in  
6-compartment  
plastic case

**STANDARD SETS:**

Each set is packed in sturdy plastic compartmented case.

UPC No. 054808

Set No. 1 18001	Set No. 2 18002	Set No. 3 18003	Set No. 11 18011	Set No. 13 18013	Set No. 15 18015
<b>SIZES INCLUDED:</b>					
--	--	--	--	#4*	#4*
--	--	--	1/8"	#5*	#5*
--	--	--	--	#6*	#6*
--	--	--	--	#8	#8
3/16"	--	--	3/16"	#10	#10
--	--	--	--	#12	#12
1/4"	1/4"	--	1/4"	1/4"	1/4"
5/16"	5/16"	5/16"	5/16"	5/16"	5/16"
3/8"	3/8"	3/8"	3/8"	3/8"	3/8"
7/16"	7/16"	7/16"	7/16"	7/16"	7/16"
1/2"	1/2"	1/2"	1/2"	1/2"	1/2"
--	5/8"	9/16"	5/8"	5/8"	5/8"
--	--	5/8"	3/4"	3/4"	3/4"
--	--	--	7/8"	--	7/8"
--	--	--	1"	--	1"

\* 3-Flute style supplied for sizes shown. All others in 4-Flute style.



**STANDARD SETS:  
Nos. 11, 13, 15**

Packed in  
15-compartment  
plastic case

**PLASTIC SET CASES (empty):**

For Set Nos. 1, 2, 3..... 18501

For Set Nos. 11, 13, 15..... 18511

**⚠ California Proposition 65 Warning**

**WARNING:** These products contains lead, a chemical known to the State of California to cause cancer, and birth defects or other reproductive harm.

For more information: [www.P65Warnings.ca.gov](http://www.P65Warnings.ca.gov).

# TAP EXTRACTORS

## for PIPE TAPS



860-523-5231 • Fax: 860-236-9968 • WaltonTools.com

UPC No. 054808

### SINGLE UNITS and REPLACEMENT PARTS

WALTON Pipe Tap Extractor Size	COMPLETE EXTRACTOR		EXTRA FINGERS	
	5-Flute	4-Flute	5-Flute	4-Flute
1/8"	20125	20124	22125	22124
1/4"	20255	20254	22255	22254
3/8"	20375	20374	22375	22374
1/2"	20505	20504	22505	22504
3/4"	20755	--	22755	--
1"	21005	--	23005	--

*EDP Part No. shown indicates available flute style for each size.*

**WALTON** Tap Extractors, designed to fit Pipe Taps, are stocked in the standard sizes and flute styles shown above.



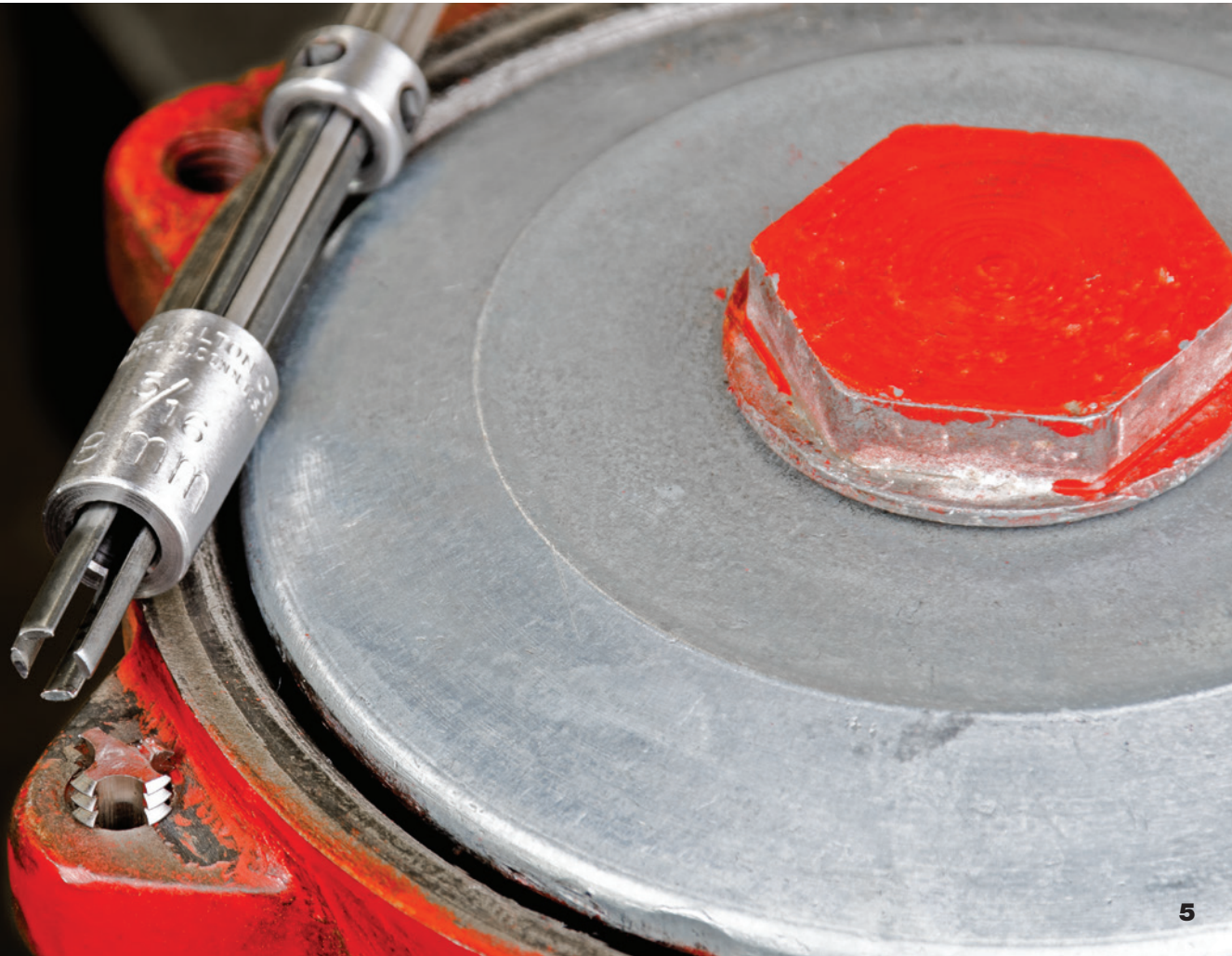



**REFER TO ORDERING INFORMATION ON PAGE 7.**





UPC No. 054808

## SINGLE UNITS and REPLACEMENT PARTS

WALTON STI Extractor Size	COMPLETE TAP EXTRACTOR			EXTRA FINGERS		
	4-Flute	3-Flute	2-Flute	4-Flute	3-Flute	2-Flute
						
#4 STI	--	30043	30042	--	32043	32042
#5 STI	--	30053	30052	--	32053	32052
#6 STI	--	30063	30062	--	32063	32062
#8 STI	--	30083	30082	--	32083	32082
#10 STI	--	30103	30102	--	32103	32102
#12 STI	--	30123	30122	--	32123	32122
1/4" STI	30254	30253	30252	32254	32253	32252
5/16" STI	30314	30313	--	32314	32313	--
3/8" STI	30374	30373	--	32374	32373	--
7/16" STI	30434	--	--	32434	--	--
1/2" STI	30504	--	--	32504	--	--
9/16" STI	30564	--	--	32564	--	--
5/8" STI	30624	--	--	32624	--	--

EDP Part No. shown indicates available flute style for each size.

**WALTON** Tap Extractors, designed to fit all wire screw thread insert STI taps, are stocked in the standard sizes and flute styles shown above.

**REFER TO ORDERING INFORMATION ON PAGE 7.**

 **California Proposition 65 Warning**

**WARNING:** These products contains lead, a chemical known to the State of California to cause cancer, and birth defects or other reproductive harm.  
For more information: [www.P65Warnings.ca.gov](http://www.P65Warnings.ca.gov).

# TAP EXTRACTORS & EXTENSIONS

## IMPORTANT ORDERING INFORMATION



860-523-5231 • Fax: 860-236-9968 • WaltonTools.com

## TAP EXTRACTORS

1. Do not use the abbreviation "EXT." on your orders. This could refer to either "Extensions" or "Extractors."
2. All orders for complete Tap Extractors and all replacement parts must clearly specify the flute style required. Each table shows, by size, the flute style for which that size is standard. Parts are not interchangeable between the different flute styles.
3. When ordering replacement parts, refer to the parts illustration on page 2 for correct part name.
4. Standard Sets contain sizes and flute styles as shown on page 4. Order by Set Number. Sets containing the same sizes but in non-standard flute styles will be made up on request at no extra charge.
5. Orders for Pipe Tap Extractors and replacement parts must clearly specify "Pipe Tap" and indicate required flute style.
6. Orders for STI Tap Extractors and replacement parts must clearly specify "STI" (Screw Thread Insert) and indicate flute style required.
7. Threads per inch need not be specified, as Tap Extractors will fit both NC and NF taps.



## TAP EXTENSIONS

1. Do not use the abbreviation "EXT." on your orders. This could refer to either "Extensions" or "Extractors."
2. **Please note that Style A Tap Extensions have been discontinued.** Style B Tap Extensions are great for both machine and hand tapping.
3. Tap Extensions are packaged and priced individually (except Set No. 9).
4. Orders for Pipe Tap Extensions must clearly specify "Pipe Tap."
5. Size 1/8" Pipe Taps are available with either .3125 dia. shanks or .4375 dia. shanks. We have two different sizes of Pipe Tap Extensions to fit these. Please specify which size is required.